

Functional description



**Control keypads Motion Assist
Motion Assist Pro**

Revisions

Version	Date	Modification, change
(-)	12/10	First release
(a)	12/11	Operation

Disclaimer and Exclusion of Liability

PHOENIX MECANO is not responsible for damage resulting from:

- failure to observe these instructions,
- changes made to this product which have not been approved by PHOENIX MECANO, or
- the use of replacement parts which have not been approved or manufactured by PHOENIX MECANO.

Manufacturer's address

DEWERT Antriebs- und Systemtechnik GmbH
Weststraße 1
32278 Kirchlengern
Germany
Tel: +49(0)5223/979-0
Fax.: +49 0 522375182
<http://www.dewert.de>
Info@dewert.de

Address of distributor

OKIN Motion Technologies GmbH
Friedrich-Ebert-Straße im Campus 1
51429 Bergisch Gladbach
Germany
Tel: +49(0)2204/48022-0
Fax.: +49(0)2204/48022-118
<http://www.okin.de>
Info@okin.de



Revisions	3
Disclaimer and Exclusion of Liability	3
Manufacturer's address	3
Address of distributor	3
1. General information.....	6
1.1 About these instructions	6
1.2 Conventions used in this manual	7
2. Safety Instructions	8
2.1 Proper and Intended Usage.....	8
3. Description of Control Keypads	10
3.1 Function of the Control keypads	10
4. Installation.....	12
4.1 Installation procedure	12
4.2 Electrical connection	13
5. Operation of the Motion Assist Control Keypad	14
5.1 Operating Notes	14
5.2 Memory positions.....	14
5.3 Container stop positions	15
5.4 What to do in the event of an error.....	16
6. Operation of the Motion Assist Pro Control Keypad	17
6.1 Raising and lowering the table	19
6.2 Child Lock	19
6.3 Turning the optional lighting on and off	19
6.4 Memory Positions	19
6.5 Container stop positions	20
6.6 Toggling the motor groups (optionally when more than three lifting columns are present)	21
6.7 Setting the clock.....	22
6.8 Height display of the table.....	23
6.9 What to do in the event of an error.....	24

7. Troubleshooting	25
8. Maintenance	26
EU Declaration of Conformity	28

1. General information

1.1 About these instructions

The following description is a specific operating manual for the control keypads Motion Assist and Motion Assist Pro (referred to as Motion Assist (Pro) in this document). The following description is not an operating manual for the end product and should only be used in conjunction with the installation manual for the Motion Manager 2 / 3 control units and the instructions for the Inlinedrive ID11 system.

	 CAUTION
	<p>The notices in these instructions must be followed! Following the guidelines during installation and connection procedures will help to minimize:</p> <ul style="list-style-type: none">• the risk of accident and injury, and• damage to the drive system or the end product.

This functional description has been created with due care and attention. Unless otherwise required by law, we do not guarantee that the data, images and drawings are accurate or complete nor do we accept liability for their contents.







- ▶ We reserve the right to make unannounced technical changes in the course of our continual product improvement process!

1.2 Conventions used in this manual

Notices which do not relate to safety are indicated in these instructions with a triangle:

- ▶ Triangular notice symbol



Explanations of warning notices

	 DANGER
	DANGER indicates a hazardous situation which, if not avoided, will result in death or serious injury.
	 CAUTION
	Warning of a dangerous situation, possible consequences: light or minor injuries.
	 WARNING
	Warning of a dangerous situation, possible consequences: death or serious injury.
	NOTICE
	Notice about a harmful situation, possible consequences: the product itself or surrounding objects could be damaged.

2. Safety Instructions



2.1 Proper and Intended Usage



The PHOENIX MECANO control keypads Motion Assist (Pro) will be used to operate of lifting columns for adjusting the height of tables.



 CAUTION	
The control keypads Motion Assist (Pro) are only designed for use as described above. Any other form of usage is not permitted and can lead to accidents or destruction of the unit. Such non-approved applications will lead immediately to the expiration of all guarantee and warranty claims on the part of the end-product manufacturer against the manufacturer.	

Improper usage

Be sure to follow the notices below concerning improper usage. You should include them in your product manual in order to inform the users of your end product.

 WARNING	
The Motion Assist (Pro) control keypads should not be used <ul style="list-style-type: none"> • near high-frequency surgical equipment or defibrillators, • in any environment where combustible or explosive gases or vapours (e.g., anaesthesiology) may be present, • in a humid environment or outdoors, or • in tables that will be cleaned with an automated washing system. 	

 CAUTION	
The Motion Assist (Pro) keypad should not be used <ul style="list-style-type: none"> • by small children, • by frail or infirm persons without supervision, or • in the proximity of small children. 	



 CAUTION	
You should only use spare parts which have been manufactured or approved by PHOENIX MECANO. Only these parts will guarantee a sufficient level of safety.	

Product labelling

- ▶ The ratings plate shown is an example. The data shown in the illustration may differ from those of your control unit.



Rating plates (examples)

M. Assist	Type designation (abbreviation)
Motion Assist Pro	Model name
xxxxx	Article No:
U in: 24V	Input voltage
Prod.date 28/10	Calendar week / year
Vx.xx	Software version
Serial No.	Serial number of the handset
IP 20	Protection degree
	Use in dry rooms only!
	Follow all special disposal instructions!

3. Description of Control Keypads

The Motion Assist (Pro) control keypads are supplied for making adjustments to tables using lifting columns. The keypads are mounted on the front edge of the table. The variants of the control keypads differ in the number of keys for the various operating functions.

3.1 Function of the Control keypads

3.1.1 Motion Assist Control Keypad

The Motion Assist control keypad has two keys for movements up and down. In conjunction with a corresponding control unit other functions are possible, that allow you to start with pre-programmed positions. The programming of these positions will also be done using the Motion Assist control keypad.

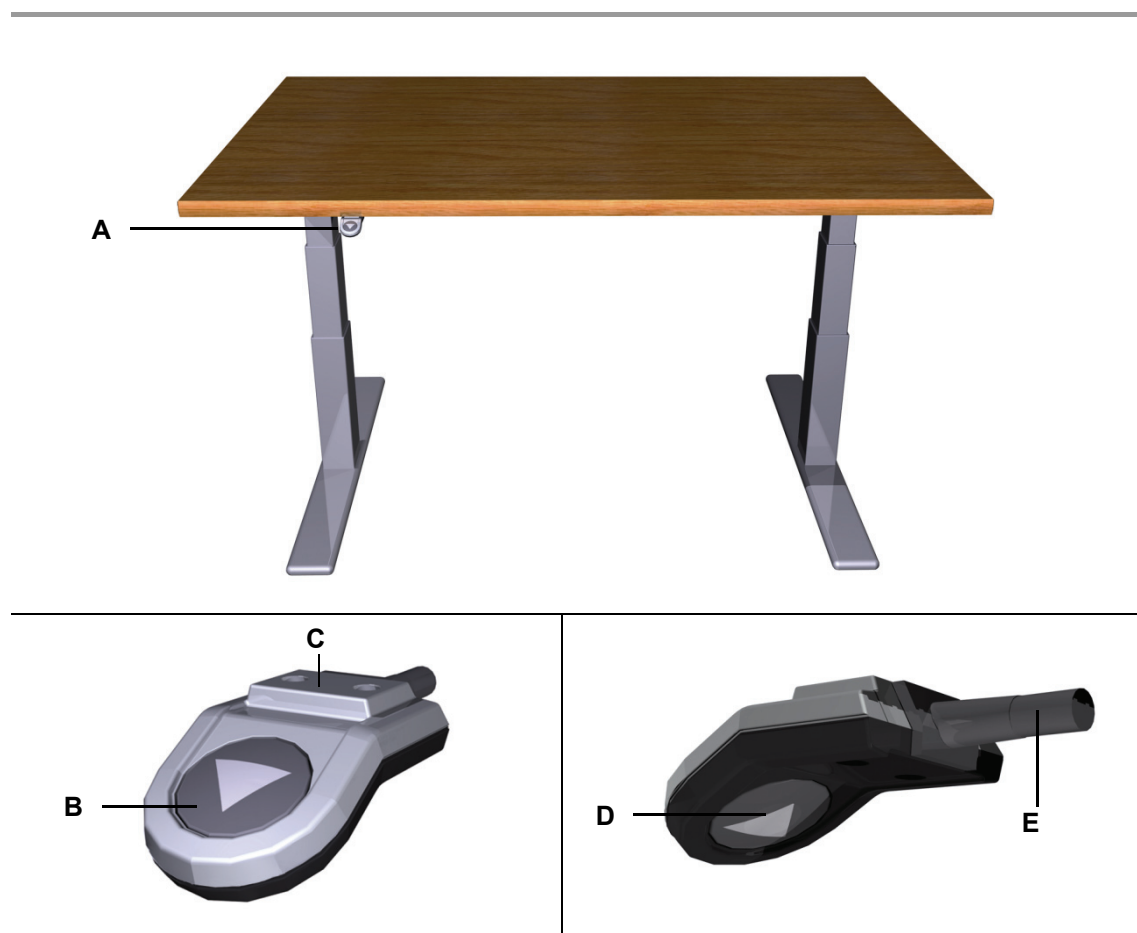

Motion Assist control keypad

A Control Keypad

C Mounting surface

E Connection cable

B ▼-button (adjusting downward)

D ▲-button (upward adjustments)

3.1.2 Motion Assist Pro Control Keypad

The control keypad Motion Assist Pro has keys to adjust up and down as well as function keys to go to pre-programmed positions, or for additional functions (displacement measurement, time display and other functions). The programming of these positions is also done using the Motion Assist Pro control keypad.

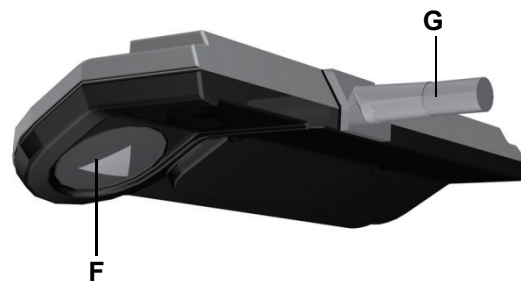
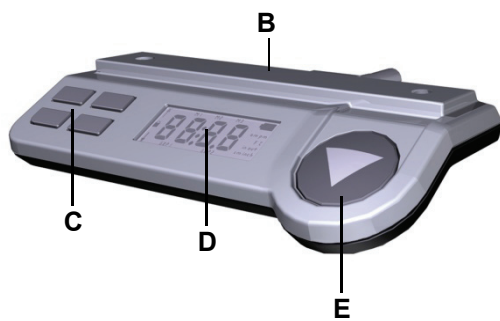

Motion Assist Pro Control Keypad

- A** Control Keypad
- B** Mounting surface
- C** Keys for memory positions
- D** Display
- E** ▼-button (adjusting downward)
- F** ▲-button (upward adjustments)
- G** Connection cable

4. Installation

4.1 Installation procedure

4.1.1 Installation of the Motion Assist Control Keypad

The Motion Assist control keypad is mounted with two screws under the table (under the front edge of the table).

- Use screws meeting the requirements of DIN 7981 with \varnothing 3.9 mm and of suitable length (10 mm plus the screw-in depth into the table), screw head \varnothing 7.5 mm.

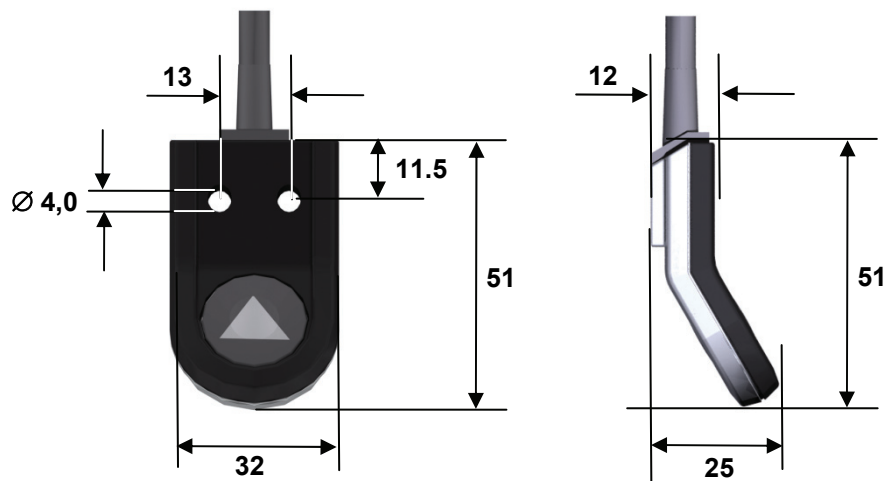

Motion Assist control keypad, installation dimensions (in mm)

4.1.2 Installation of the Motion Assist Pro Control Keypad

The Motion Assist Pro control keypad is mounted with two screws under the table (under the front edge of the table).

- ▶ Use screws meeting the requirements of DIN 7981 with \varnothing 3.9 mm and of suitable length (10 mm plus the screw-in depth into the table), screw head \varnothing 7.5 mm.

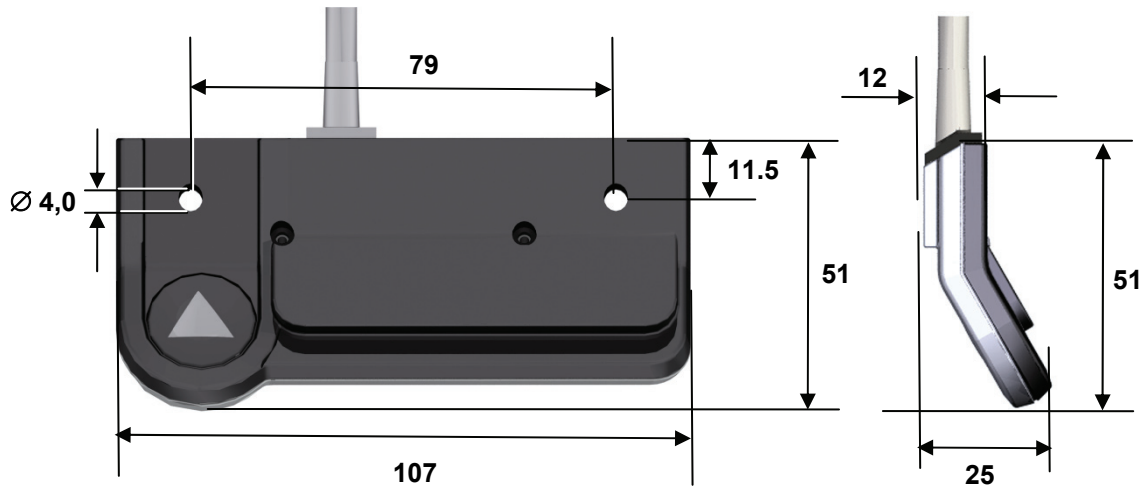

Motion Assist control keypad, installation dimensions (in mm)

4.2 Electrical connection

4.2.1 Connection of the control keypad to the controller

- ▶ Information on how to connect the control keypad to the Motion Manager 2 / 3 control units can be found in the system manual of the Inlinedrive ID11 system.

5. Operation of the Motion Assist Control Keypad

The Motion Assist control keypad has ▲ and ▼ keys to make adjustments.

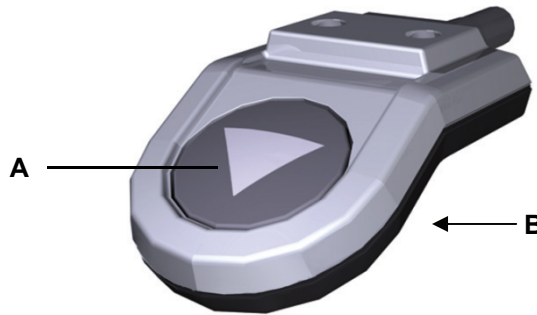

Function keys of the Motion Assist Control Keypad

A ▼-button (adjusting downward)

B ▲-button (adjusting upward) on the underside of the keypad

5.1 Operating Notes

Raising and lowering the table

Press the corresponding key on the keypad to raise or lower the table. Keep pressing the key until the desired height of the table is reached.

Turning the optional lighting on and off

Tap the ▼ or ▲ key briefly to turn the lighting on or off.

5.2 Memory positions

You can program two memory positions of the table. When adjusting the height of the table, it stops automatically when it reaches the preprogrammed memory position.





- ▶ When programming the container stop position (see Section 5.3 "Container stop positions ") the memory positions are over-written!

5.2.1 Moving to the Memory position

Press the ▼ or ▲ key and keep holding until the desired memory position is reached.

- ▶ You can move past the memory positions. To move beyond a memory position, press the key again and hold it until the desired table position is reached.

5.2.2 Programming the Memory Positions

- 1 Press the  or  key and keep holding until the desired position is reached.
- 2 Press both keys simultaneously for more than 5 seconds to save the position. A double click sound indicates that the control unit is in storage mode.
- 3 Store the Memory position:
 - Upper memory position: Press  key until you hear a triple click.
 - Lower memory position: Press  key until you hear a triple click.
- 4 The memory positions are now saved.





5.3 Container stop positions

You can program two end positions of the table (container stop positions). The table stops at a container stop position, if they are programmed. The table cannot be moved beyond these positions.

NOTICE	
	Programming a container stop position is useful, a lower one for example, to prevent damage if there is equipment or other items stored or mounted under the table. This protection is not afforded by setting a memory position since they can be overridden by pressing the key again.

- ▶ If there is a requirement to reset the drive control unit during operation, the container stop positions should be disabled before starting the drive reset.

5.3.1 Programming of the container stop positions

- ▶ Any stored memory positions are overwritten when the container stop positions are programmed!
- 1 Press the  or  key and keep holding until the desired container stop position is reached.
 - 2 Press both keys simultaneously for more than 5 seconds to save the position. A double click sound indicates that the control unit is in storage mode.
 - 3 Save the position as follows:
 - Upper container stop position: Press  key until you hear a triple click.
 - Lower container stop position: Press  key until you hear a triple click.
 - 4 Pull out the controller's power plug from the plug socket.
 - 5 The status LEDs on the Motion Manager 2 / 3 control unit will briefly flash. Wait until the status LEDs go out.
 - 6 Press and hold the  key while you insert the power plug of the controller, keep pressing it until you hear a double click.
 - 7 The chosen container stop position is now enabled and can no longer be exceeded.



5.3.2 Disabling the container stop positions



- 1 Pull out the controller's power plug from the plug socket.
- 2 The status LED on the Motion Manager 2 / 3 control unit will briefly flash. Wait until the status LEDs go out.
- 3 Press and hold the  key while you insert the power plug of the controller, keep pressing it until you hear a double click.
- 4 The container stop positions are now disabled.

5.4 What to do in the event of an error

A fault is indicated by one or more of the status LEDs on the control unit blinking. If an error occurs during operation (e.g. during table height adjustment) a drive reset must be carried out.

5.4.1 Drive Reset following problems occurring during operation of the Motion Assist control keypad

	 CAUTION
	Electrical components should be connected or disconnected only when the power supply cord is unplugged.

- ▶ If a container stop position is programmed, it must be disabled before the drive reset (see action steps 1 through 3). If no container stop position is programmed, skip steps 1 to 3 and start with step 4.
- 1 Pull out the mains power plug.
 - 2 The status LEDs light up briefly. Wait until the status LEDs go out.
 - 3 Reconnect the mains power plug. Press  key immediately after plugging the power cord until you hear a double click sound, this indicates that the container stop positions are disabled. The container stop positions are now disabled.
 - 4 Press  key for more than 5 seconds to perform the drive reset. The lifting columns move with reduced speed.
 - 5 Adjust all the lifting columns until they are fully retracted (move the table to it's lowest position!).
 - 6 After a few seconds the status LEDs will go out. This indicates that the control is operational again. You can now press the corresponding position to raise or lower the lifting columns.
 - 7 You can also reprogram any container stop positions (see "Programming the Memory Positions" in Section "Container stop positions ")

6. Operation of the Motion Assist Pro Control Keypad

The Motion Assist Pro control keypad has, apart from the ▲ and ▼ keys, four function keys (1, 2, 3, M) and a display which shows the active settings and the time.



Motion Assist Pro Control Keypad Function Keys

- | | |
|---|---|
| A Key "1" for memory position M1 | B Key "2" for memory position M2 |
| C Key "3" for memory position M3 | D Key "M" used when programming the memory positions |
| E ▼-button (adjusting downward) | F ▲-button (adjusting upwards) on the underside |
| G Display | |



Motion Assist Pro Control Keypad Display

Display	Explanation
↑	Upper end position (container stop position)
↓	Lower end position (container stop position)
🔒	Child Lock
GRP1	Display: Motor Group 1
GRP2	Display: Motor Group 2
M1	M1 indicates memory position 1
M2	M2 indicates memory position 2
M3	M3 indicates memory position 3
ampm	Clock display mode
cm inch	Table Height display
---9	Fault has occurred, error code e.g. "9"

6.1 Raising and lowering the table

Press the corresponding key on the keypad (▲ or ▼) to raise or lower the table. Keep pressing the key until the desired height of the table is reached.

6.2 Child Lock

Turning on the child lock

- 1 Press the ▲ key and the "3" button simultaneously for 3 seconds. 🔒 flashes in the display for 3 seconds.
- 2 Activate the child lock by pressing the ▼ and ▲ keys simultaneously while it is flashing. 🔒 is now permanently on in the display. The keypad is now disabled.

Turning off the child lock

- 1 Press the ▲ key and the "3" button simultaneously for 3 seconds. 🔒 flashes in the display for 3 seconds.
- 2 Deactivate the child lock by pressing the ▼ and ▲ keys simultaneously while it is flashing. 🔒 is no longer shown in the display. The keypad is now unlocked.

6.3 Turning the optional lighting on and off

Tap the ▼ key briefly to turn the back-light on or off.

6.4 Memory Positions

You can program three memory positions of the table. When adjusting the height of the table, it stops automatically when it reaches a preprogrammed memory position.

- ▶ You can move past the memory positions. To move beyond a memory position, press the ▼ or ▲ key again and hold it until the desired table position is reached.
- ▶ Memory positions can not be deleted, only overwritten.

6.4.1 Moving to the Memory position



Press key "1", "2" or "3" and hold it until the desired memory position is reached. The display will show **M1**, **M2** or **M3** which indicates the memory position has been reached. This will be displayed as long as the key is pressed.

6.4.2 Programming the Memory Positions

- 1 Press the ▼ or ▲ key and keep holding until the desired table position is reached.
- 2 Briefly press the "M" button. The display will blink and show M1, M2 and M3 simultaneously for 3 seconds. While flashing, press the button "1", "2" or "3" to save the memory position.
- 3 The display will show M1, M2 or M3 to indicate that the position has been saved.

6.5 Container stop positions

You can program two end positions of the table (container stop positions). The table stops at a container stop position, if they are programmed. If an end position is reached, the display will indicate this by a blinking arrow.







- top position: 
- bottom position: 

The table cannot be moved beyond these positions.

NOTICE	
	Programming a container stop position is useful, a lower one for example, to prevent damage if there is equipment or other items stored or mounted under the table. This protection is not afforded by setting a memory position since they can be overridden by pressing the key again.



- ▶ If there is a requirement to reset the drive control unit during operation, the container stop positions should be disabled before starting the drive reset.

6.5.1 Programming the container stop positions

- 1 Press the  or  key and keep holding it until the desired container stop position is reached.
- 2 Save the position as follows:
 - Upper container stop position: Press the "M" and the  keys simultaneously for more than 5 seconds.
 - Lower container stop position: Press the "M" and the  keys simultaneously for more than 5 seconds.
- 3 The chosen container stop position is now enabled and can no longer be exceeded. The display is will indicate if a position
 - has been programmed as the upper end position: 
 - has been programmed as the lower end position: 

6.5.2 Disabling the container stop positions

Press the ▼ or ▲ key and keep holding it until the container stop position you wish to disable is reached. Reaching the container stop position is shown in the display by the following arrow flashing:

- top position: 
 - bottom position: 

- 1 Press the "M" and the ▼ keys (lower end-position) or the ▲ keys (upper end-position) simultaneously for more than 5 seconds to disable the current container stop position.
- 2 The disabled container stop position is no longer shown in the display.

6.6 Toggling the motor groups (optionally when more than three lifting columns are present)

6.6.1 Activating the toggling function of the motor groups

- 1 Press and hold the "1" and "2" keys simultaneously for more than 5 seconds. The display blinks for three seconds showing **GRP1** and **GRP2**.
- 2 Press ▲ and the ▼ keys simultaneously for a short time while the **GRP1 GRP2** flashes in the display. The display now permanently shows **GRP1**. The toggling function is now active and motor group 1 is active.

6.6.2 Changing the motor group

If you have activated the toggling function of the motor groups, you can choose between motor group 1 (synchronous operation of motor output 1 and 2 of the controller) and motor group 2 (motor output 3 of the controller).

- 1 Press the ▲ and ▼ keys simultaneously for 3 seconds. The controller switches to the other motor group. The display shows **GRP1** when motor group 1 is activated and **GRP2** when motor group 2 is activated.

6.6.3 Deactivating the motor group toggling function

- ▶ You should only turn off the toggling function when a synchronous operation of all three motor outputs from the control unit is possible.
- 1 Press and hold the "1" and "2" keys simultaneously for more than 5 seconds. The display blinks for three seconds showing GRP1 and GRP2.
 - 2 Press ▲ and the ▼ keys simultaneously for a short time while the GRP1 GRP2 flashes in the display. The active motor group display, GRP1 or GRP2 will no longer be shown. The toggle function is now disabled.
 - 3 Perform a drive reset to restore synchronous operation. The procedure to do this is described in section 6.9 "What to do in the event of an error".

6.7 Setting the clock

NOTICE	
	<ul style="list-style-type: none">• Before commissioning, set the clock. For more information about commissioning, refer to the system manual for the Inlinedrive ID11 system.• You should also set the clock following a power failure.

Choosing between 12 and 24 hour display, setting the time

- The following steps only describe the use of the ▼ key. Instead of the ▼ key, the ▲ key can also be used.
- 1 Press the "2" and "3" buttons simultaneously for three seconds or until **am** or **pm** blink in the display (12 hour) or neither of them (24 hour display).
 - 2 Press the ▼ key until **am**, **pm** or neither is displayed.
 - Permanent display **am**: 12-hour clock (time setting in the morning).
 - Permanent display **pm**: 12-hour clock (time setting in the afternoon).
 - nothing displayed: 24-hour clock.
 - 3 Press the "1" key. The hour display will flash. Set the hours using the ▼ key.
 - 4 Press the "1" key. The minute display will flash. Set the minutes using the ▼ key.
 - 5 Press "1" again to leave the menu. The time is displayed as set.

6.8 Height display of the table







6.8.1 Metric or imperial measurements

Press the "M" key for 4 seconds. The displayed unit of the table height changes.

- ▶ The factory default setting is in centimetres. By pressing the "M" key (4 seconds) you can toggle between the units, cm and inches.

6.8.2 Changing the measured height of the table

The standard height of 68.0 cm is installed in the Motion Assist Pro control keypad when manufactured. If the actual height of the table is different, you can change the setting manually. Following this adjustment the actual display of the table height will be displayed in the Motion Assist Pro correctly.

- ▶ The following steps only describe the use of the  key. Instead of the  key, the  key can also be used.
- 1 Press "1" and the "3" button simultaneously for 5 seconds until the first number flashes in the display. Press the  key until the first digit of the height is correctly shown in the display.
 - 2 Press the "1" key. The second digit of the height flashes in the display. Set the second digit using the  key.
 - 3 Press the "1" key. The third digit of the height flashes in the display. Set the third digit using the  key.
 - 4 Press the "1" key. The last digit of the height flashes in the display. Set the last digit using the  key.
 - 5 Press "1" again to leave the menu.





6.9 What to do in the event of an error

A fault is indicated by one or more of the status LEDs on the control unit blinking. If an error occurs during operation (e.g. during table height adjustment) a drive reset must be carried out.

6.9.1 Drive Reset following problems occurring during operation of the Motion Assist Pro control keypad

	CAUTION
	Electrical components should be connected or disconnected only when the power supply cord is unplugged.

	NOTICE
	Before starting to re-commission, set the clock of the Motion Assist Pro keypad. To set the clock, please refer to section 6.7 "Setting the clock".

- ▶ If a container stop position is programmed, it must be disabled before the drive reset (see action steps 1 through 3). If no container stop position is programmed, skip steps 1 to 3 and start with step 4.
- 1 A programmed container stop position must be disabled before the reset trip. Press the  key and keep holding it until the container stop position you wish to disable is reached. Reaching the container stop position is shown in the display by the appropriate arrow flashing:
 - Achieving the lower end position: 
 - 2 Press the "M" and the  keys (lower end position) simultaneously for more than 5 seconds to disable the container stop position.
 - 3 The disabled container stop position is no longer shown in the display.
 - 4 Press the  button and hold it until the lifting columns are fully retracted, this will be indicated by a 5-fold clicking sound. The drive reset is then successfully concluded.

7. Troubleshooting

Problem	Possible cause	Solution
The lifting column or control unit is not functioning.	There is no mains supply voltage.	Connect the mains power. Perform a drive reset.
	Lifting column, control keypad or control unit is defective.	Please contact your supplier or sales agent.
The lifting column suddenly no longer moves.	The overheating protection or system protection has been triggered.	Remove the overload (change or remove the load). Check for any objects that are obstructing the movement of the table. Allow the system to rest for 20 to 30 minutes. If this does not resolve the problem, contact your supplier or distributor.
	The unit's fuse may have been triggered.	Please contact your supplier or sales agent.
	There is no mains supply voltage.	Connect the mains power.
	A cable has been disconnected (mains power, lifting column or control keypad).	Check the cables and reinsert them, if required.
One or more status LEDs are blinking on the control unit.	Malfunction of the corresponding lifting column(s).	Check the lifting column connection cable. Perform a drive reset. If this does not resolve the problem, contact your supplier or distributor.
All status LEDs are blinking on the control unit.	Power failure during lifting column operation.	Perform a drive reset. If this does not resolve the problem, contact your supplier or distributor.

8. Maintenance

Type of check	Explanation	Time interval
Check the function and safety of the electrical system.	A qualified electrician should carry out this inspection.	Periodic inspections can be carried out at intervals based on the risk assessment which you conduct for your end product.
Look over the housing periodically for any signs of damage.	Check the housing for breaks or cracks. The IP-class protection will be impaired by any breakage or cracks.	At least every six months.
Look over the plug-in connections and electrical access points for signs of damage.	Check that all electrical cables and connections are firmly seated and correctly positioned.	At least every six months.
Look over the cables for any signs of damage.	Check the connecting cables for pinching or shearing. Also check the strain relief and kink protections mechanisms, in particular after any mechanical load.	At least every six months.
Periodic functional test of the control keypad.	Move the drive to the end positions in order to test the end switches.	At least every six months.

Cleaning and care

The Motion Assist (Pro) control keypad is designed to make it easy to clean. The smooth surfaces can be conveniently cleaned.

	NOTICE
	Never clean the Motion Assist (Pro) control keypad in an automated washing system or with a high-pressure cleaner. Do not allow fluids to penetrate the lighting. Damage to the control keypad could result.

- 1 Unplug the Motion Assist (Pro) from the control unit before cleaning.
- 2 Use a standard cleanser that is suited for plastics when cleaning the Motion Assist (Pro) control keypad, or use a moist cloth. Follow the usage instructions provided with the cleanser.
- 3 Be sure that you do not damage the connecting cables during the cleaning.

	NOTICE
	Do not use a cleanser that contains benzene, alcohol or similar solvents.

EU Declaration of Conformity

In compliance with Appendix IV of the EU EMC Directive 2004/108/EC

The manufacturer:

DEWERT Antriebs- und Systemtechnik GmbH

Weststraße 1

32278 Kirchlengern

Germany

declares that the following products

Motion Assist with DEWERT drive system
Motion Assist Pro with DEWERT drive system

meet the requirements of the following EU directives:

Electromagnetic Compatibility Directive 2004/108/EC

Applied standards:

- EN 55014-1/A1:2009
- EN 55014-2/A2:2008
- EN 61000-3-2/A2:2009
- EN 61000-3-3:2008

This declaration of conformity is no longer valid if constructional changes are made which significantly change the keypad (i.e., which influence the technical specifications found in the instructions or the intended use)!



Kirchlengern, on the 09.12.2011

Sascha Koltzenburg
Head of R & D

OKIN Motion Technologies GmbH
Friedrich-Ebert-Straße im Campus 1
51429 Bergisch Gladbach, Germany
Tel: +49(0)2204/48022-0
Fax.: +49(0)2204/48022-118
<http://www.okin.de>
Info@okin.de

ID No.: 67998